

* V means 1500V module

HT72-156M
HT72-156M(V)

NEW

Big Size: Cell 158.75*158.75

380W / 385W / 390W
395W / 400W / 405W



- Module Efficiency: 20.1%
- No. of Cells: 72 (6 × 12)
- Weight: 22.5kg
- Dimensions: 2008mm×1002mm×35mm

Monocrystalline
158.75 × 158.75mm



Shanghai Aerospace Automobile
Electromechanical Co., Ltd.
website: www.htsolar.com.tr



Factory :
Turkey HT Solar Energy Joint Stock Company
Lianyungang ShenZhou New Energy Co., Ltd.

PID
PID Resistant



Designed for high voltage systems of up to 1500 VDC, increasing the string length of solar systems and saving on BoS costs



Advanced surface treatment, lower surface reflection and 5BB cell design can reduce the series resistance and improve the module efficiency

1000Pa

Certified to withstand dynamic mechanical load 1000 Pascal



Microcrack resistant
Triple EL tested of high quality control.



Entire module certified to withstand extreme wind (2400 Pa) and snow loads (5400 Pa)



Ammonia / Salt Mist
Corrosion resistant

2%

All the modules are sorted and packaged by amperage, reducing mismatch losses and maximizing system output.

Comprehensive and first-rate certification system

IEC61215: 2016, IEC61730: 2016 Latest Standard and UL 1703 Latest Standard, ISO9001, ISO14001 and OHSAS18001, meeting the highest international standards
Strict quality control



IEC 61215
IEC 61730
Regular Production
Surveillance
www.tuv.com



380W/385W/390W/395W/400W/405W

• Engineering Drawing

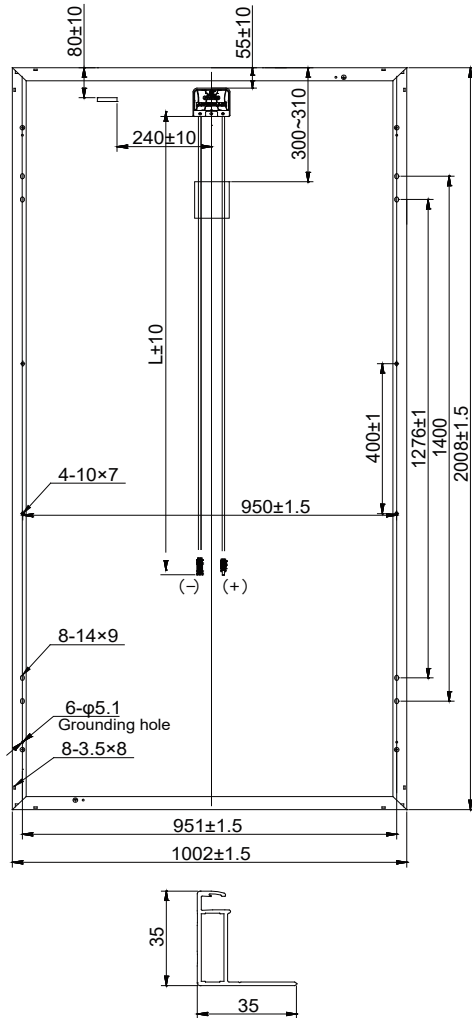

• Electrical Characteristics

| Module | HT72-156M / HT72-156M(V) | | | | | |
|---------------------------------|--------------------------|--------|--------|--------|--------|--------|
| Maximum Power at STC(Pmax) | 380W | 385W | 390W | 395W | 400W | 405W |
| Open-Circuit Voltage(Voc) | 48.3V | 48.4V | 48.5V | 48.6V | 48.7V | 48.8V |
| Short-Circuit Current(Isc) | 10.34A | 10.47A | 10.55A | 10.67A | 10.79A | 10.91A |
| Optimum Operating Voltage (Vmp) | 39.9V | 40.1V | 40.3A | 40.5V | 40.7V | 40.9V |
| Optimum Operating Current(Imp) | 9.53A | 9.61A | 9.68A | 9.76A | 9.84A | 9.91A |
| Module Efficiency | 18.9% | 19.1% | 19.4% | 19.6% | 19.9% | 20.1% |
| Power Tolerance | 0 ~ +5W | | | | | |
| Maximum System Voltage | 1000V / 1500V DC(UL/IEC) | | | | | |
| Maximum Series Fuse Rating | 15/20A | | | | | |
| Operating Temperature | -40 °C to +85 °C | | | | | |

*STC: Irradiance 1000W/m², module temperature 25 °C, AM=1.5
Optional black frame or white frame module according to customer requirements

• NOCT

| Module | HT72-156M / HT72-156M(V) | | | | | |
|-------------------------------|--------------------------|-------|-------|-------|-------|-------|
| Maximum Power | 281W | 285W | 289W | 293W | 296W | 300W |
| Open Circuit Voltage (Voc) | 45.6V | 45.7V | 45.8V | 45.9V | 46.0V | 46.1V |
| Short Circuit Current (Isc) | 8.35A | 8.45A | 8.52A | 8.62A | 8.71A | 8.81A |
| Maximum Power Voltage (Vmp) | 37.7V | 37.9V | 38.1V | 38.3V | 38.5V | 38.6V |
| Maximum Circuit Current (Imp) | 7.45A | 7.52A | 7.59A | 7.65A | 7.69A | 7.77A |
| NOCT | 45°C ± 2°C | | | | | |

*NOCT: Irradiance 800W/m², ambient temperature 20 °C, wind speed 1 m/s

• Mechanical Characteristics

| | |
|-------------------------|-----------------------------------------|
| Solar Cells | Monocrystalline 158.75 × 158.75mm |
| No. of Cells | 72 (6 × 12) |
| Dimensions | 2008mm × 1002mm × 35mm |
| Weight | 22.5kg |
| Front Glass | High transmission tempered glass |
| Frame | Anodized aluminium alloy |
| Junction Box | IP68 |
| Cable | 4mm ² (UL/IEC) Length:1200mm |
| Connectors | MC: Compatible |
| Packaging Configuration | 30pcs / box, 715pcs / 40'HQ Container |

• Temperature Characteristics

| | |
|---------------------------------|-------------|
| Temperature Coefficient of Pmax | -0.355%/ °C |
| Temperature Coefficient of Voc | -0.275%/ °C |
| Temperature Coefficient of Isc | +0.063%/ °C |

• I-V Curves

Current-Voltage & Power-Voltage Curve

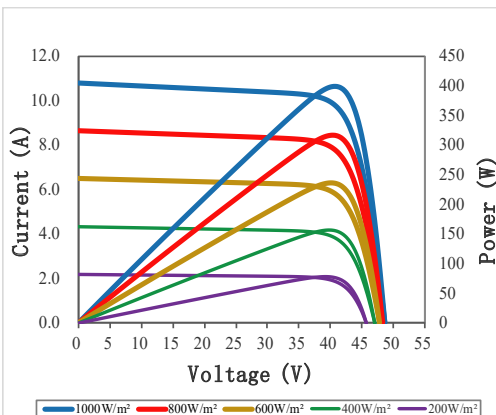

• Warranty

- 12-year product warranty
- 25-year warranty on power output
- Specific information is referred to the product quality guarantee

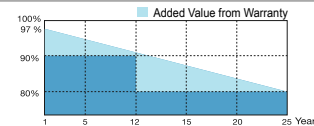

• Information Box